

1-1/2" Land Pressure Regulator

Series L20517

Features

- ▶ Original Shear-Seal® technology
- ▶ High flow capacity
- ▶ Large regulated pressure range
- ▶ Tolerates contaminated media
- ▶ Fail-safe motor control options
- ▶ Self venting
- ▶ Surge dampening

Applications

- ▶ Land-based oil drilling controls
- ▶ BOP control units
- ▶ Pressure sensitive equipment



General Specifications*

Pressure: Supply/Inlet Pressures: 3,000 psi (207 bar) 5,000 psi (345 bar) Regulated Pressure Range at 3,000 psi Supply Pressure: High Sensitivity: 300 - 1600 psi (21 - 110 bar) Full Range: 300 - 2800 psi (21 - 193 bar) Regulated Pressure Range at 5,000 psi Supply Pressure: High Sensitivity: 500 - 1600 psi (34 - 110 bar) Full Range: 500 - 3000 psi (34 - 207 bar) Media: Hydraulic Oil Fluid Temperature Range: -30° to +185°F (-34° to +85°C) Inlet Proof Pressure: 7,500 psi (517 bar) Case Proof Pressure: 4,500 psi (310 bar)	Materials of Construction: Body, Flanges, & Spring Housing: Phosphate coated carbon steel/ ductile iron Slide, Inlet, Vent, & Blocking Plates: 400 Series stainless steel Hardware: Plated alloy steel, 300 series stainless steel O'ring Material: Buna N Backup Ring Material: PTFE Socket Head Screws: Zinc plated alloy steel (std.) Wetted Parts: Stainless steel
Flow: Flow Rate: 120 GPM (@ 50 ft/s) Cv Inlet: 17.5 Cv Vent: 1.6	Pneumatic Pilot Motor ("F" prefix): Pilot Motor Working Pressure: 80 - 120 psi (5.5 - 8.3 bar) Porting A & B: 1/4" NPT Operating Temperature Range: -30° to +185°F (-34° to +85°C)
Porting: Supply 1: 1" NPT Standard, SAE Optional Supply 2: 1" NPT Standard, SAE Optional Outlet (Regulated): 1-1/2" NPT Standard, SAE Optional Vent: 1" NPT Standard, SAE Optional	Hydraulic Pilot Motor ("G" prefix): Pilot Motor Working Pressure: 400 - 1600 psi (6.9 - 110 bar) Porting A & B: SAE for 3/8" Tube (Size -6) Operating Temperature Rating: -30° to +185°F (-34° to +85°C)
* See product configurator for additional options.	Approximate Shipping Weight: Manual Unit: 70 lbs. (31.8 kg) Pneumatic Motor Unit: 90 lbs. (40.8 kg) Hydraulic Motor Unit: 90 lbs. (40.8 kg)

1-1/2" Land Pressure Regulator

Series L20517

Technical Drawings

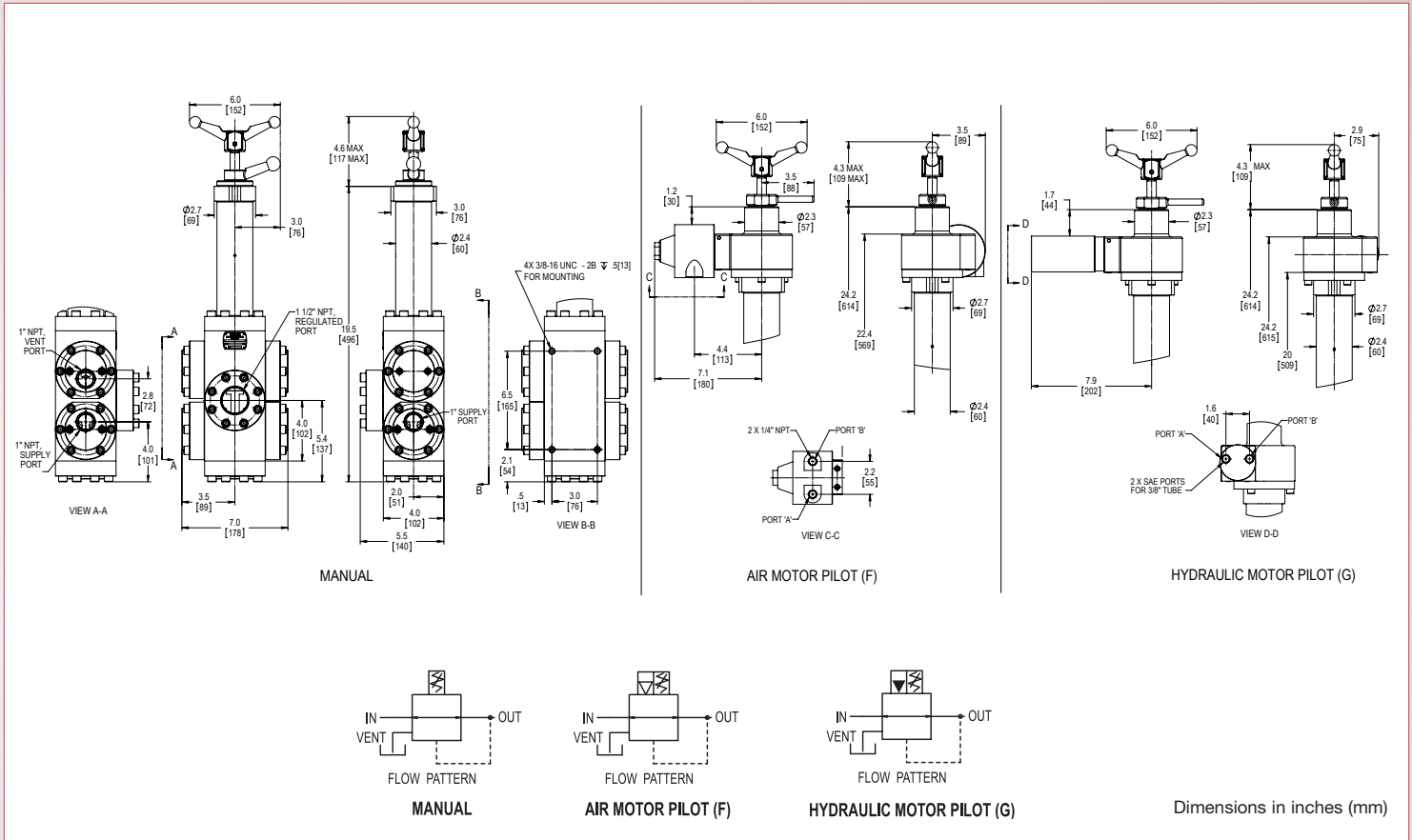

Product Configurator

Example: **L** **20517S6HQ2**

L Land pressure regulator

Option
 Blank NPT porting
 -MS SAE porting

Adjustment Method

Blank	Manual
F	Pneumatic failsafe motor
G	Hydraulic failsafe motor

Regulated Pressure Range

		Inlet Pressure	Regulated Range
Blank	High sensitivity	3000 psi	300 - 1600 psi (21 - 110 bar)
		5000 psi	500 - 1600 psi (34 - 110 bar)
-1	Full range	3000 psi	300 - 2800 psi (21 - 193 bar)
		5000 psi	500 - 3000 psi (34 - 207 bar)

Series
 20517S6HQ2 1-1/2" Land pressure regulator



* Please visit Bertrem Valve's Website to see more valves that address industry needs with uncompromising quality