

# NELSON™ HEAT TRACING SYSTEMS

## ALT-CMD CONTINUITY MONITOR DEVICE

### INSTALLATION INSTRUCTIONS

#### DESCRIPTION

The ALT-CMD continuity monitor device is used to monitor bus continuity on a parallel type heater cable. After the heater cable is installed on the pipe, connect the ALT-CMD to the opposite end of the power connection kit.

#### KIT CONTENTS

- |                   |                     |
|-------------------|---------------------|
| 1 CMD Device      | 1 Power Termination |
| 1 Conduit Locknut | 1 Box Adapter       |
| 1 Sealing Grommet | 1 Gasket            |
| 1 Stand-off       | 1 Tube of Silicone  |
| 1 Label           | 2 Pipe Clamps       |
| 2 Wire Nuts       |                     |

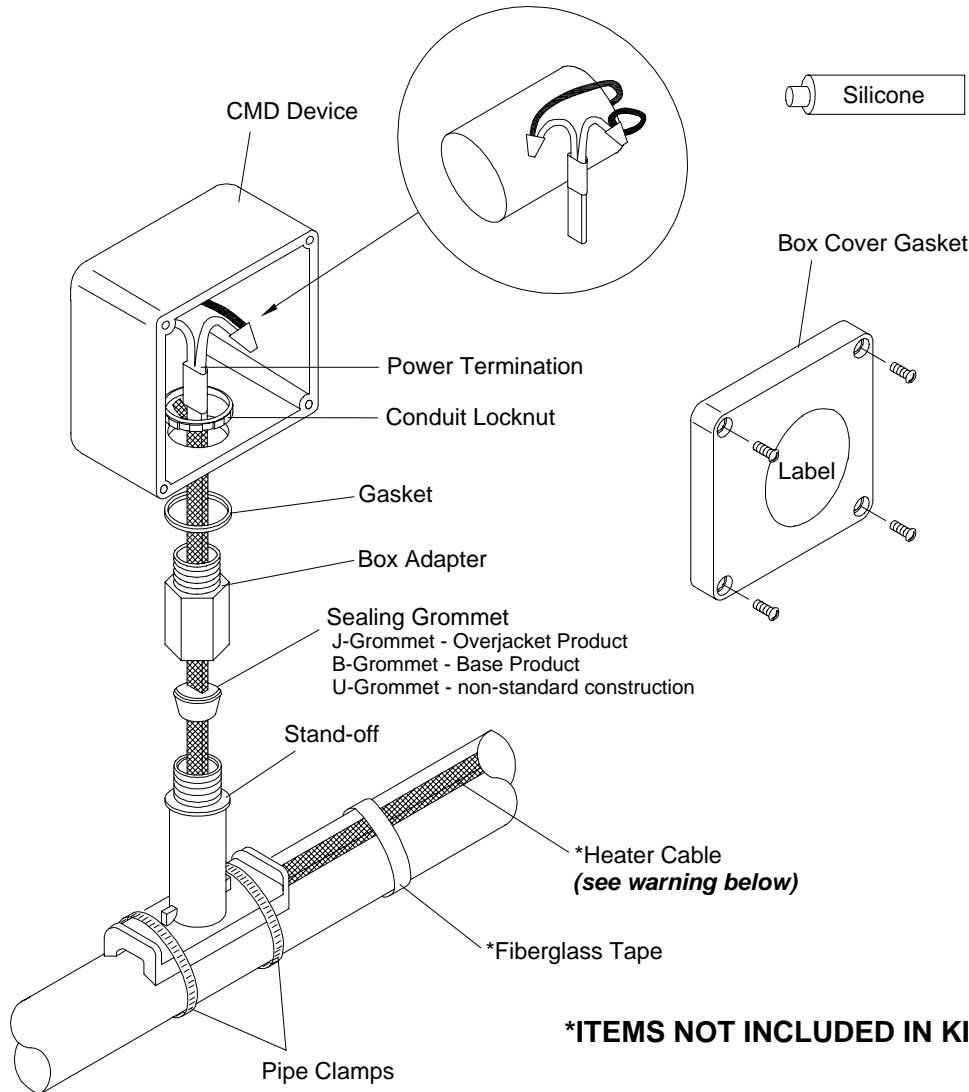

**\*ITEMS NOT INCLUDED IN KIT**

**Note:** This detail shows Braided "CB" Products only. For Overjacket "J" or "JT" Products see diagram on sheet 8.

#### **⚠ WARNING:**

Article 427-22 of the National Electrical Code requires that all heaters shall have metal coverings and be provided with branch circuit ground-fault protection.

### STAND-OFF POSITIONING

#### Section View A A

(recommend installing at the  
4 or 8 o'clock positions.)

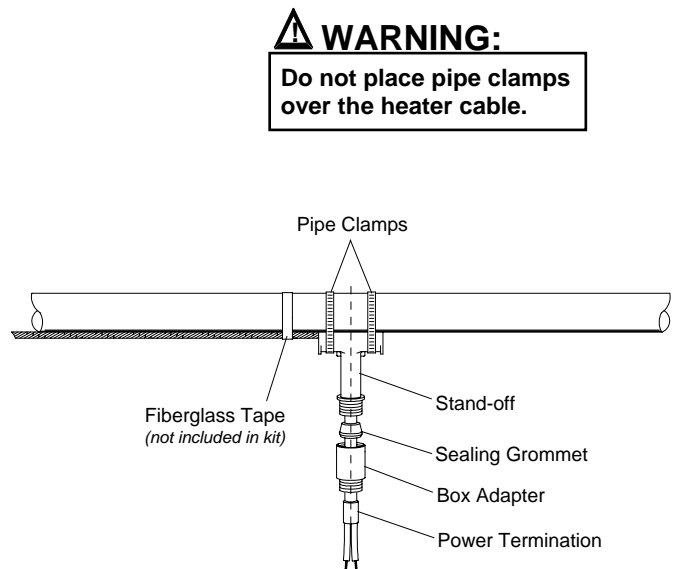
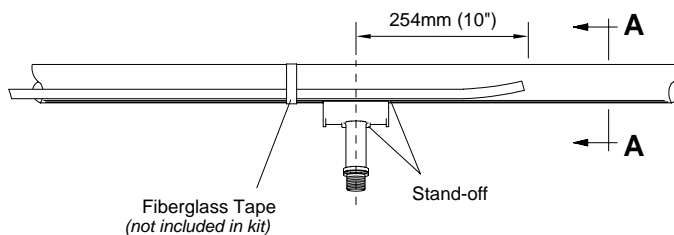
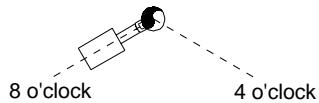

- 1 Mark pipe where stand-off will be mounted.
- 2 Push heater cable through bottom opening of stand-off.
- 3 Slide the sealing grommet over the heater cable and position inside stand-off opening:

#### for Braided "CB" Products:

See "Grommet Installation for Braided "CB" Products", sheet 3.

#### for Overjacket "J" or "JT" Products

Proceed with step 4 below.

- 4 Apply silicone around the heater cable on top of the sealing grommet and fill any voids in sealing grommet.
- 5 Slide the box adapter over the heater cable and tighten securely to stand-off.
- 6 Prepare heater cable for power termination:  
for Braided "CB" Products, see sheet 3.  
for Overjacket "J" or "JT" Products, see sheet 4.
- 7 Terminate heater cable, see sheet 7.

#### SEALING GROMMET INSTALLATION FOR BRAIDED “CB” PRODUCTS

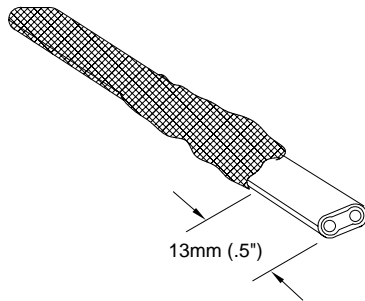

- 1 Slide braid back, allowing at least 13mm (.5") of heater cable exposed.
- 2 Cut and remove 13mm (.5") of heater cable.

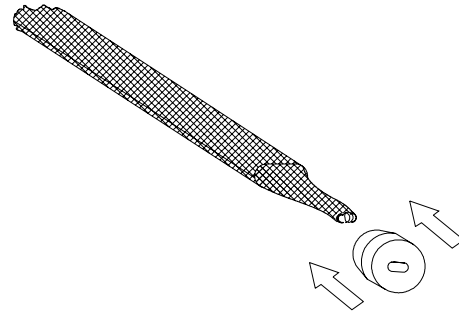

- 3 Slide braid back over heater cable and twist excess braid into a pigtail.
- 4 Slide the sealing grommet over the heater cable and position inside stand-off opening.
- 5 Continue with step 4 on sheet 2.

#### BRAIDED “CB” PRODUCTS

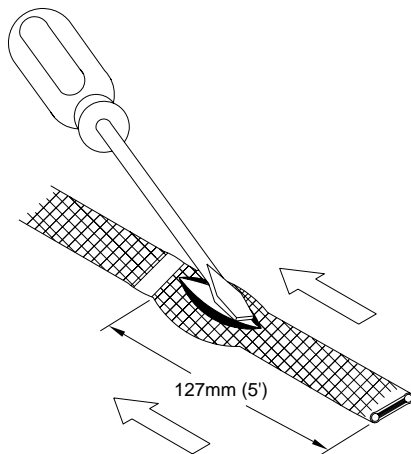

- 1 Secure cable braid with fiberglass tape.
- 2 Slide braid back 127mm (5") to create a bulge.
- 3 At the bulge, separate the braid to make an opening.

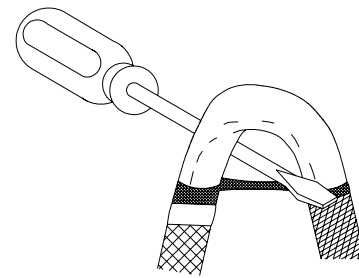

- 4 While bending the heater cable, work it through the braid opening.

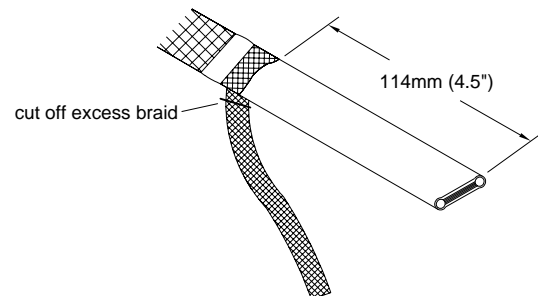

- 5 Pull the braid tight.
- 6 Cut off excess braid.
- 7 Proceed to “LT, CLT & HLT Products”, sheet 5

OVERJACKET "J" or "JT" PRODUCTS

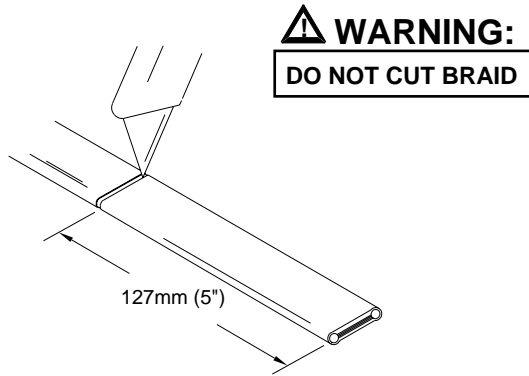

- 1 Lightly cut around cable overjacket 127mm (5") from the end. Bend cable to break the overjacket.
- 2 Lightly cut overjacket up the center between first cut mark and the cable end. Bend cable to break the overjacket.

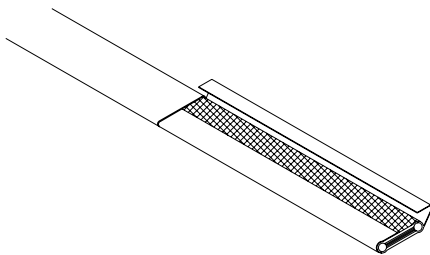

- 3 Remove overjacket from heater cable.

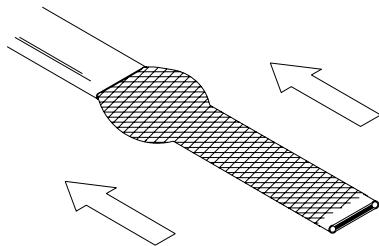

- 4 Move braid back toward the overjacket, creating a bulge.

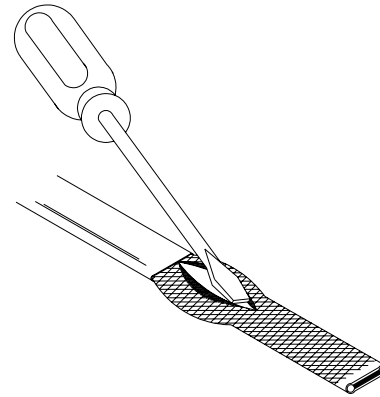

- 5 At the bulge, separate the braid to make an opening.

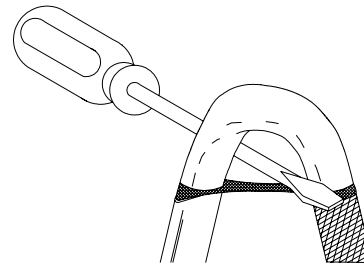

- 6 While bending the heater cable, work it through the braid opening.

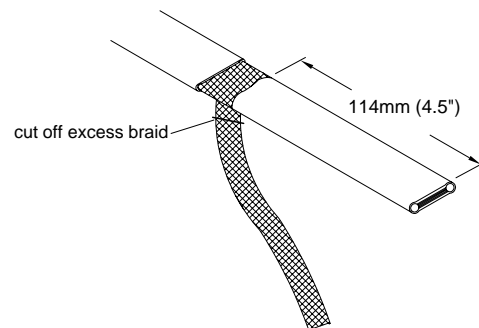

- 7 Pull the braid tight.
- 8 Cut off excess braid.
- 9 Proceed to "LT, CLT & HLT Products", sheet 5.

# NELSON™ HEAT TRACING SYSTEMS

## ALT-CMD CONTINUITY MONITOR DEVICE

### INSTALLATION INSTRUCTIONS

#### FOR ALL NELSON LT, CLT & HLT PRODUCTS

(See sheet 6 for an alternate stripping method for HLT products.)

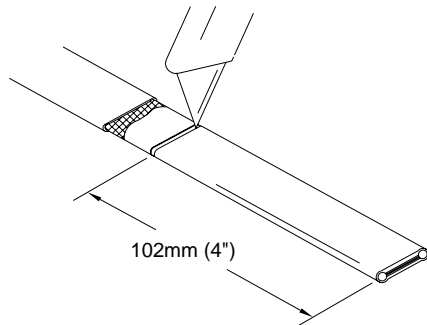

- 1 Lightly cut around cable outer jacket 102mm (4") from the end. Bend cable to break outer jacket.
- 2 Lightly cut the outer jacket up the center between the first cut mark & the cable end. Bend cable to break outer jacket.

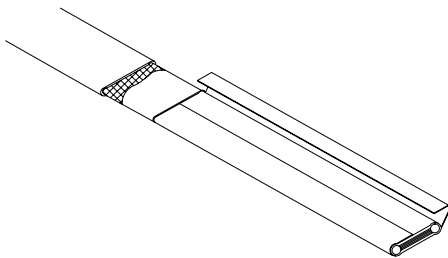

- 3 Remove the jacket from the heater cable.

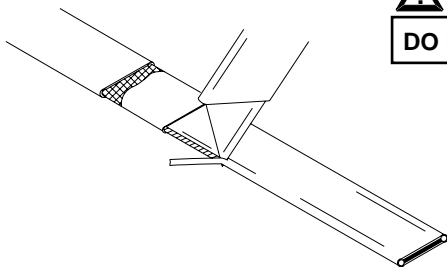

- 4 Shave the core material from the outside of each bus wire.

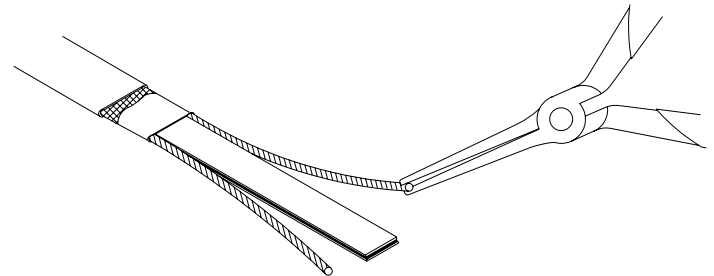

- 5 Starting at the end, pull each bus wire away from the core material.
- 6 Remove exposed core material.

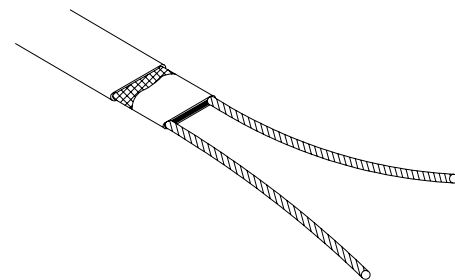

- 7 Cut 6mm (0.25") off the end of each bus wire.
- 8 Proceed to "Power Termination", sheet 7.

**⚠ WARNING:**  
**DO NOT CUT BUS WIRES**

#### HLT PRODUCTS ALTERNATE STRIPPING METHOD

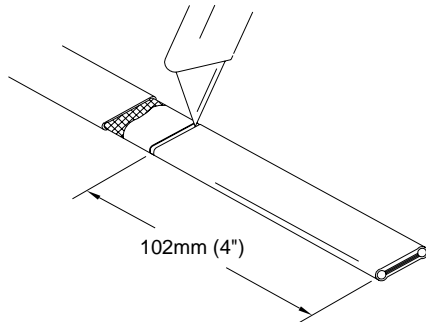

- 1 Lightly cut around cable outer jacket 102mm (4") from the end. Bend cable to break outer jacket.
- 2 Lightly cut the outer jacket up the center between the first cut mark & the cable end. Bend cable to break outer jacket.

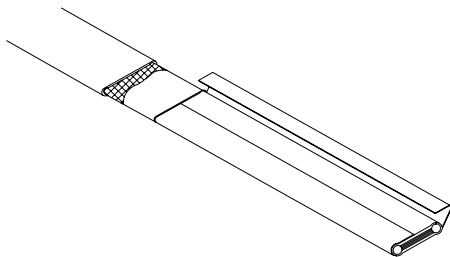

- 3 Remove the jacket from the heater cable.

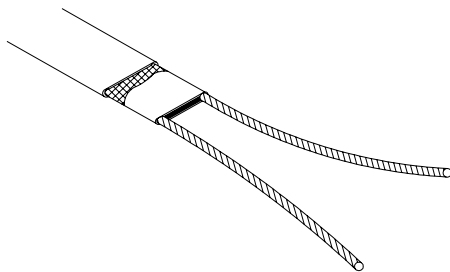

- 4 Make a cut inside each bus wire.

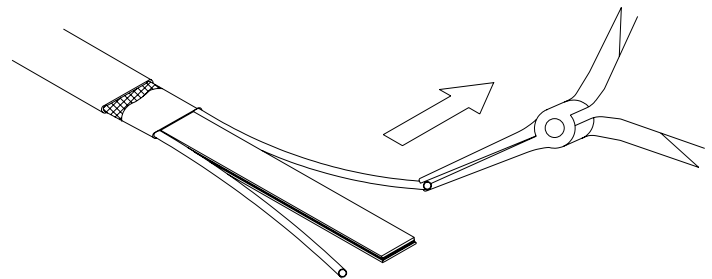

- 5 Starting at the end, in the same plane as the cable, pull each bus wire away from the core material.

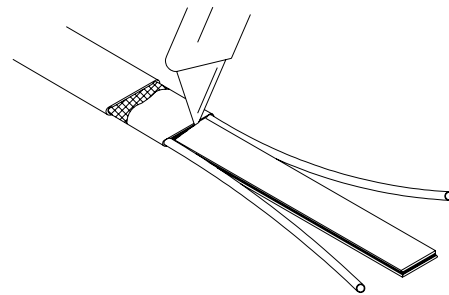

- 6 Remove the exposed core material.

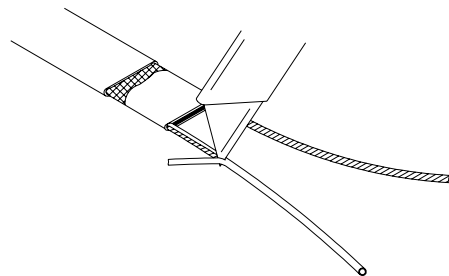

- 7 Remove the remaining core material off the outside of each bus wire.
- 8 Cut 6mm (0.25") off the end of each bus wire.
- 9 Proceed to "Power Termination", sheet 7.

**POWER TERMINATION**

**⚠ WARNING:**

Bus wires must not touch or cross while inserting into power termination.

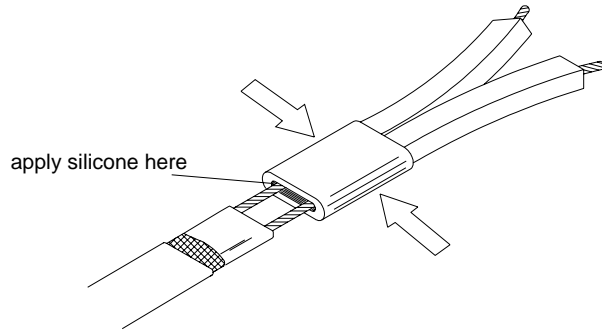

- 1 Insert bus wires into power termination.
- 2 Squeeze power termination opening and fill with silicone.

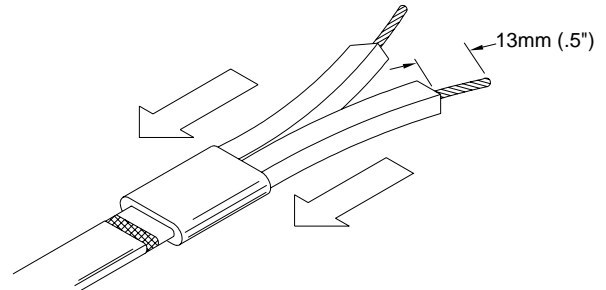

- 3 Push power termination to overlap jacket.
- 4 The silicone will set up in about 30 minutes with a complete cure after 24 hours.
- 5 Proceed to "Electrical Connection", sheet 8.

**CMD DEVICE CONNECTION**

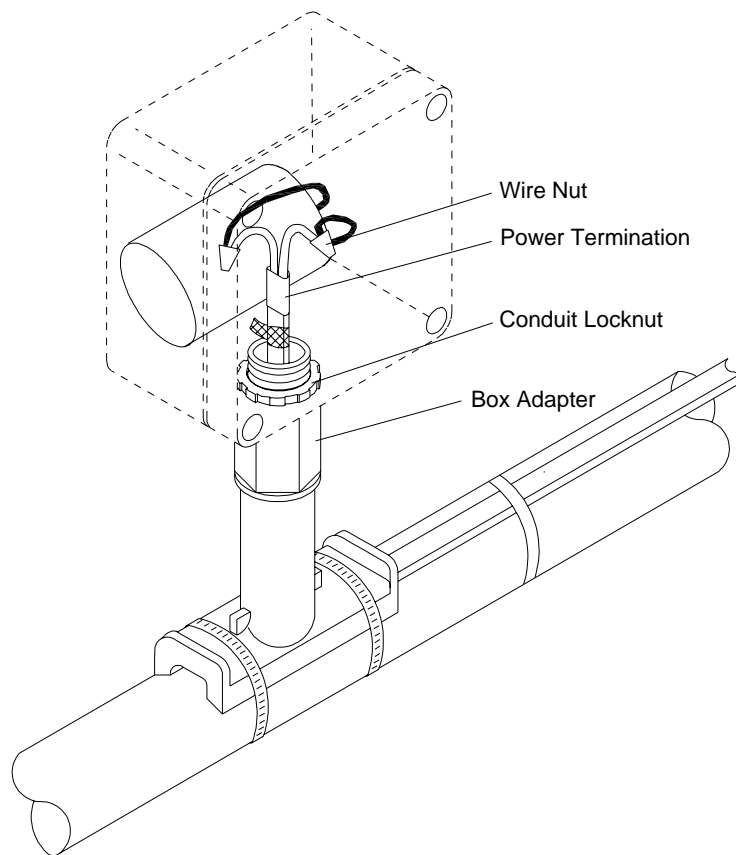

**Note:** This detail shows Overjacket “J” or “JT” Products only. For Braided “CB” Products see diagram on sheet 1.

- ❶ Place gasket onto the box adapter.
- ❷ Position the CMD device onto the box adapter and secure it with the conduit locknut.
- ❸ Connect heater bus wires together with the CMD lead wires using the wire nuts. *(See diagram above.)*
- ❹ Make sure all wires are placed inside the CMD device.
- ❺ Place the box cover and box cover gasket onto the CMD device.
- ❻ See sheet 9 for “CMD Cable Connections to CM-1 and CM-2/1”.



### CMD CABLE CONNECTIONS TO CM-1 & CM-2/1

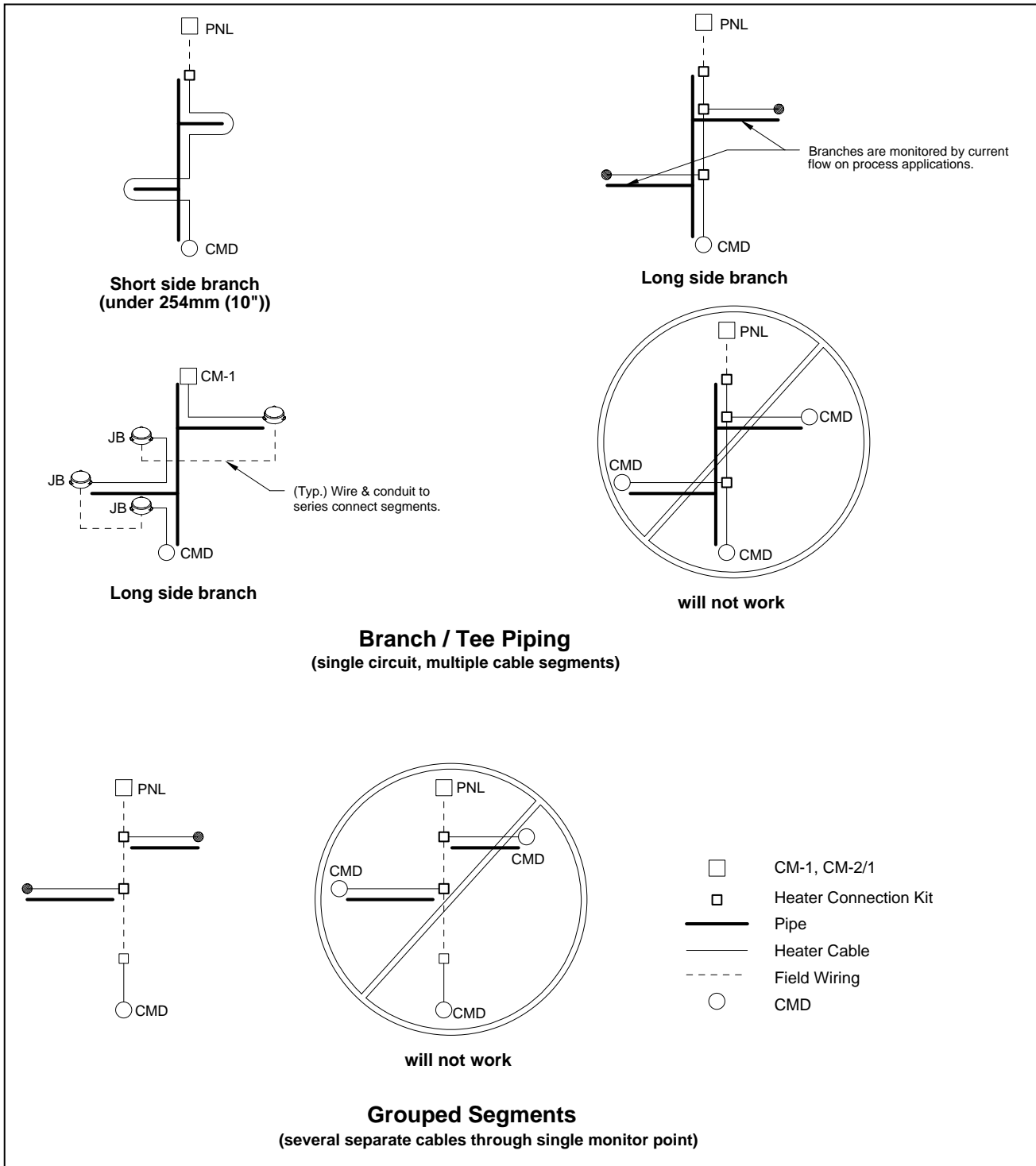

Nelson Heat Tracing Systems products are supplied with a limited warranty. Complete Terms and Conditions may be found on Nelson's website at [www.nelsonheaters.com](http://www.nelsonheaters.com).